

## Description

The upgraded new design and functions provides unbeaten performance ever. This super machine can runs with a wide range of medias. Suitable for business that are looking to build in extra capacity and more versatility.

The precise cutting system provides a helpful way in finishing industry.

## Specification

Smart System	Entry	Up and down	Pneumatic
Control Panel	Front and Rear	Roller	Silicon
Max Lam Width	1630mm/64"	Roller Diameter	130mm
Max Lam Thickness	28mm/1.1"	Trimmer Holder	2 Single 1 double Central blade
Max Speed	20m/min	Power	1600W
Heating	Top Heated	N.W.	180KGS
Max Temp	60 degrees	Dimension (LWH)	2260x860x900mm

## Unique functions

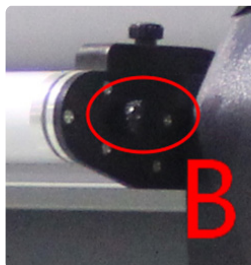

### Media tension

**A:** You can adjust the tension screw to generate extra tension for prints, keep the media in flat.

**B:** Screw B can loose or secure the tension bar.

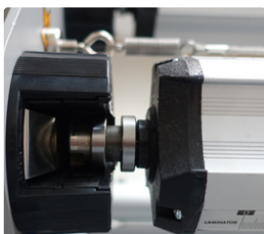

### Roll shaft

Patented new roll shaft can flip over when loading media. Also it provides possibility exchangeable with each other, with auto-locked.



### Adjustable trimmer

The tungsten safety blade can use over 20000m.

With the adjustable function, you can easily follow the cutting edges.

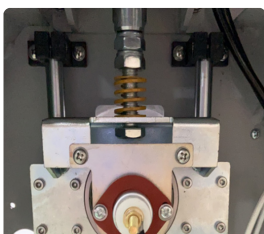

### Two rails lifting

Its two rails lifting track ensures more smooth and durable lifting.



### Rear speed controller

You may supervise the lamination starting by adjust the rear speed controller.

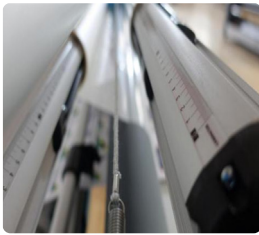

### Anti-static string



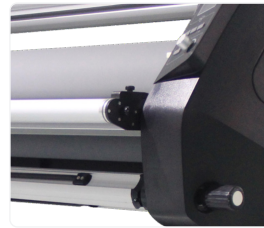





Anti-static string can eliminate most static during fast lamination.









### Tension grip

Its tension grip can be easily adjust to provide proper tension according to different medias.

## Packing list

Machine Components				
	Picture	Details	Quantity	
1		Body	1 unit	
2		Stand Legs	2 pcs	
3		Bar	3 pcs	
4		Roll	4 pcs	
5		Compressor	1 unit	
6		Foot Pedal	1 pcs	
7		Heater	3 pcs	Fragile
8		Oil-Water separator	1 pcs	

Accessories Carton				
	Picture	Details	Quantity	
1		Stand screw	1 bag	
2		Fuse	2pcs	
3		Terylene mat	2 pcs	
4		Ceramic pipe	6 sets	
5		Wrench	1 set	
6		Cutter	1pcs	
7		Roll Clip	1 set	

## Installation

### 1.1 Stand 1.Left stand leg 2.Lower two bars 3.Supporting bar 4.Right stand leg 5.

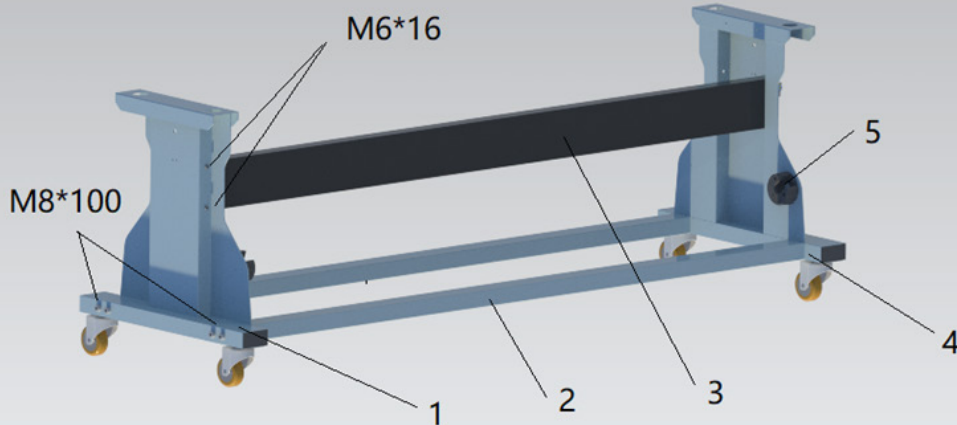

### 1.2 Machine body



## 1.3 Heater **(Caution: Please shut down the power before installation).**



**Step 1** Put heater into roller

Open left and right cover,  
remove Rubber mat

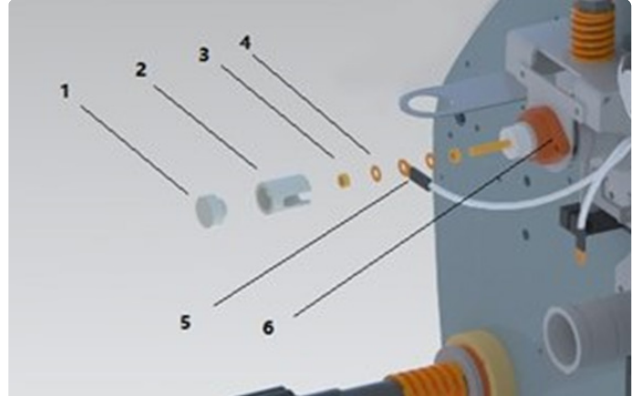

**Step 2** Lead wire

1.Ceramic cap 2.Ceramic pipe 3.Hex nut  
4.Flat mat 5.Lead wire 6.Rubber mat

## 1.4 Compresor



**Step 1**

Feed one side of air tube  
into compressor



**Step 2**

Connect the other side  
of air tube to oil-water  
separator.



**Step 3**

Press "Red" button to  
operate.

## Operation

### 2.1 Panel

1. Press speed button 3 seconds to active Heat ON/OFF
2. Turn right to select Heat ON or OFF, press again to confirm
3. (Heat ON) Press button to select "Set Temp", rotate to adjust degrees, press again to confirm the setting
4. "▶" runs continuously
5. "◻" Stop running; Foot Pedal can control roller moves
6. "⏸" Only Foot Pedal can control roller moves
7. Long pressing "▶◻" to show 30 days lamination statistics
8. Long pressing "⏸◻" to adjust settings
9. You can press rear button to run or stop
10. Over 2 mins no operate, machine will auto stop if button speed is "0"

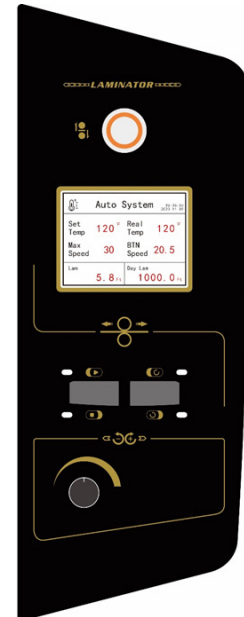

## Lamination

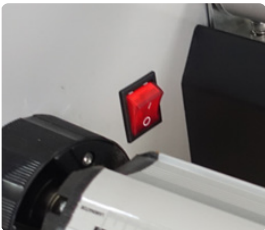

### Power ON

1

Auto System			
Set Temp	120 °C	Real Temp	120 °C
Max Speed	30	BTN Speed	20.5
Lam	5.8 m	Day Lam	1000.0 m

### Heat Up

Press speed button 3 seconds then turn right to heat on. Selected proper temperature and wait heated up.

2

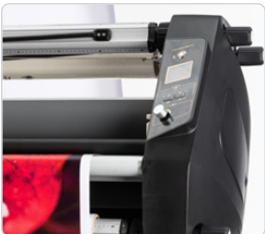

### Loading film and prints

Put 3 inch cores on liner and finish roll. After heated up, stop the machine.

3



### Lifting up roller

4

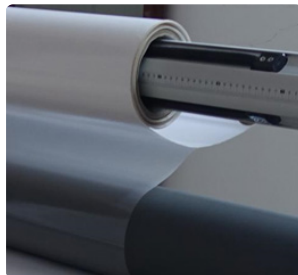
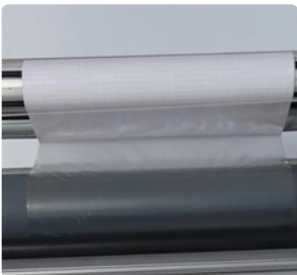

### Method A - Feeding film

Peel off film and pull it through the rollers until stick on the finish roll. (A)

*During this step, please keep the film tight.*

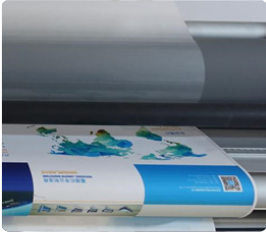

### Method A - Feeding prints

Feed prints slowly with tension through the top roller.



### Method A - Running

Lift down roller;  
Slowly running the machine or use foot pedal.

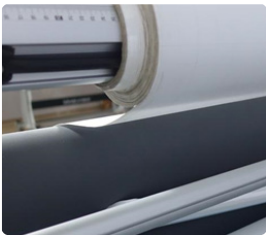

### Method B - Feeding film

Pull film with liner through the rollers. (B)

*During this step, please keep the film tight.*



### Method B - Feeding prints

Lift down roller;  
Slowly running the machine or use foot pedal.



### Method B - Peel off film liner

Use our safety knife to peel off the film liner, and stick the liner onto the liner roll.

Then lift down roller and slowly running the machine or use foot pedal.

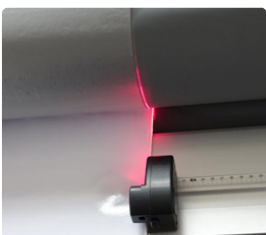

### Alignment

Keep film and media alignment.



### Notice

When the lamination starting, please be careful the if the over sized film may stick onto roller.



Lift up cutting bar.



Locked the cutter holder



Cutter adjuster.

### Cutter

If needed, you can active the cutters to trimming the edges or separate two different pictures. The cutters can be slightly adjust the distance.

## Trouble shooting

### Check roller balance

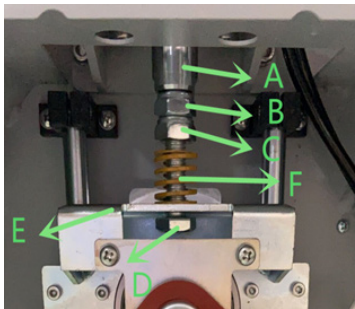
Check roller balance		
Roler balance		<p>Firstly, please make sure the roller pressure is in neutral condition(Lift down the top roller to check the gap between Spring F and Screw C, under neutral state, there should be 1-2mm same gap between F and C of both sides).</p> <p>If the gap of both sides are not the same, please use wrench to hold Bolt D, then adjust Screw C to make sure the gap of both sides are same.</p>
Pressure increase	<p>Most of materials could be laminated with the roller self-weight for good finishing. If for some special (thick) materials need more pressure, please go on the following steps:</p> <p><b>Step1.</b> Make ensure the roller is balance;  <b>Step2.</b> Lift down top roller;  <b>Step3.</b> Using wrench to hold Bolt D, then adjust Screw C downward for more pressure.</p>	

Trouble shooting		
Trouble	Defective parts	Incorrect operation
Roller can't lift up and down	Air cylinder Air Compressor Roller stuck in lifting track Lifting knob or button	Reset emergency button Air inlet speed of both cylinder
Control Panel don't light	Fuse tube Power supply	Press "SET" 3 seconds Reset emergency button
Abnormal speed	Motor Fuse tube Speed button Speed controller Central controller Laser sensor Chains (Motor shaft)	Laser sensor blocked Reset emergency button Active speed button in Front or Rear
Temperature issue	Heater Fuse tube Solid relay Temp sensor	Real temp higher than Set temp Adjust Temperature correction

Bubbles	Roller broken	Rollers balance Increase roller pressure More roll shaft tension Higher temperature Slow down speed More tension in Prints Prints not dry enough
Folds	Roller broken	Roller balance Align Prints and Film Tension in Prints / Tension in Film Roll shafts tension Prints not dry enough

## Notice

- Slowly running the machine when heated.
- Lift up roller after finish the lamination.
- Keep rollers clear.
- Do not scratch the rollers.
- Lubricate the gears and chains.
- Friction mats should be checked and replaced regularly.